

BLACK VIPER

HAND HOIST



Chain Hoist B-V

0.5Ton-30Ton

The compact and lightweight premium class hand chain hoist!
Designed for demanding applications.

- Highly shock-resistant housing, fully encapsulated against moisture and dust
- Forged hooks with reinforced safety latch
- Main axle with ball bearing to minimize effort
- Precision gear for long working life
- All unpainted parts with high-grade corrosion protection
- Low-wear sintered brake linings
- Housing with high quality powder coating
- Extensive spare parts and maintenance service

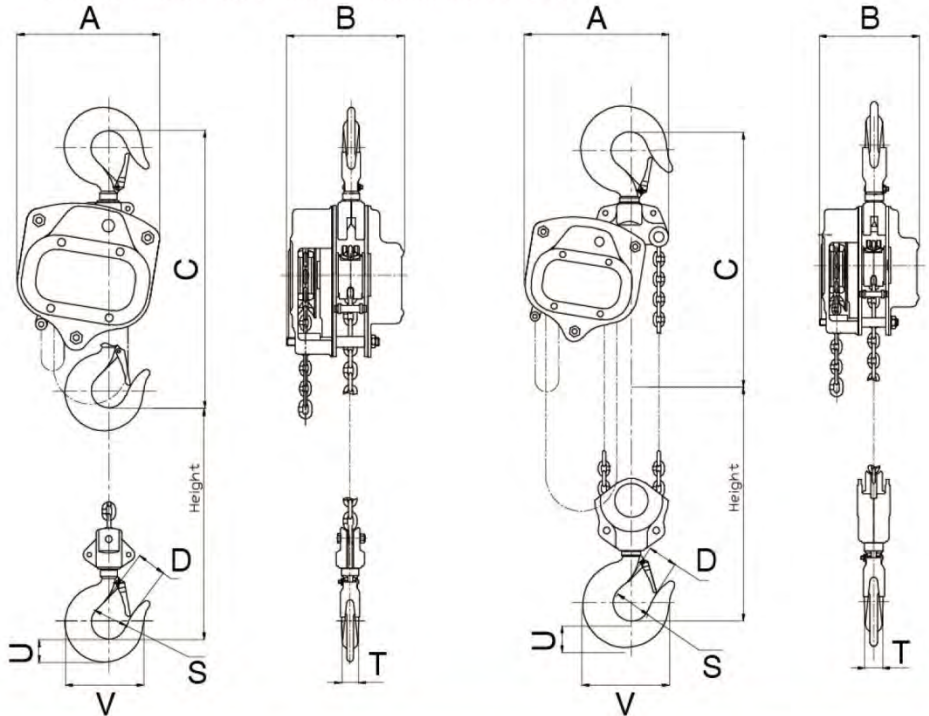

Model	Rated Load (Ton)	Standard Lift (m)	Test Load (Ton)	Efforts Required at Capacity(N)	Diameter of Load Chain (mm)	No. of Load Chains	Major Dimensions(approx)(mm)								Net Weight (kg)	Extra Weight Per Meter of extra lift(kg)
							A	B	C	D	S	T	U	V		
B-50V	0.5	2.5	0.75	262	5	1	135	124	288	20	30	11.5	18	65	7.0	1.5
B-100V	1.0	2.5	1.5	304	6	1	160	137	334	25	37	18.5	22	78	10.5	1.8
B-150V	1.5	2.5	2.25	395	8	1	195	143	415	35	45	19	26	97	15.5	2.0
B-200V	2.0	2.5	3.0	330	6	2	160	137	459	35	48	23	29	103	17	2.7
B-300V	3.0	3.0	4.5	402	8	2	195	143	536	36	50	27	38	123	23	3.2
B-500V	5.0	3.0	7.5	415	10	2	255	173	660	46	65	30	41	150	39	5.3
B-750V	7.5	3.0	11.25	428	10	3	395	173	738	45	80	40	61	215	52	7.5
B-1000V	10.0	3.0	12.5	428	10	4	395	173	738	55	80	40	61	215	69	9.8
B-1500V	15.0	3.0	18.75	447x2	10	6	410	204	1028	85					95	14.2
B-2000V	20.0	3.0	25.0	428x2	10	8	650	195	1002	80	105	60	92	285	162	19.8
B-3000V	30.0	3.0	37.5	442x2	10	12	710	398	1050	82	105	65	98	285	237	23.9