

OMEGA LINK

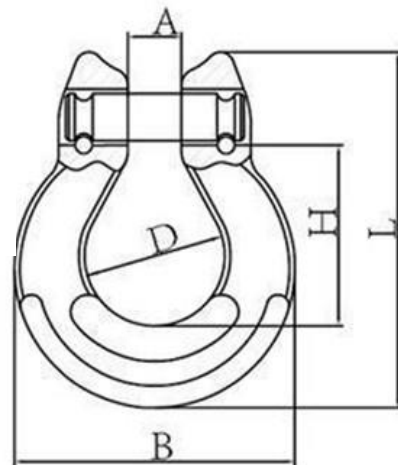

- Forged super alloy steel; Quenched & Tempered
- Suitable for EN812-2 G80 Chain
- 100% Magnaflux Crack Detection
- Individually proof-tested at 2.5X Working Load Limit
- Fatigue tested at 1.5X Working Load Limit for 20,000 cycles
- Surface Finish: Powder Plastified
- Load pins 100% inspected & tested



WWL (Tons)	Breaking Load (Tons)	Dimensions in mm					Weight (kg)
		A±0.5	B±2	D±1	H±1.5	L±2	
1.12	4.48	8	41	20.5	25	52	0.12
2	8	10	52	23.5	35	68.5	0.22
3.15	12.6	12	62	31.5	40.5	81	0.36
5.3	21.2	15	81	41	54	108	0.71
8	32	19	99	49.5	64	126	1.3
12.5	50	23	118	58	75.6	152	2.2