

OPEN WEDGE SOCKET

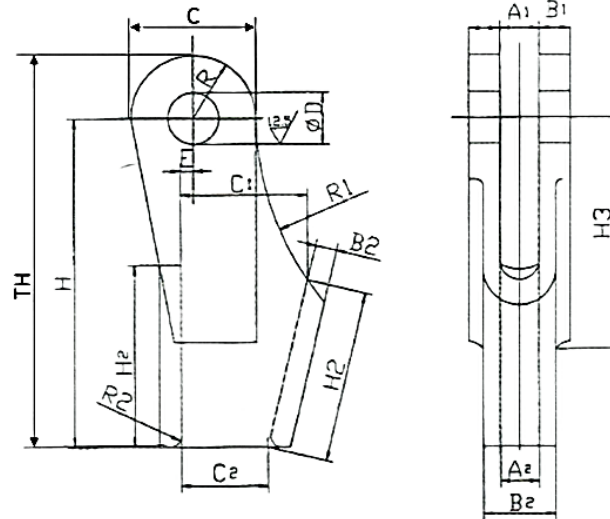

- High tensile steel, cast basket & forged pin
- Hot dipped galvanized finish
- Quenched & Tempered
- Min. Breaking Load, MBL is 5X Working Load Limit, WLL

Dimensions in MM, unless specified otherwise



WLL (TONS)	DIA. (MM)	TH	H	A1	ØD	B1	C	WEIGHT (KG)
1.25	7-8	129	110	18	16	9	36	0.8
2	9-10	165	142	21	20	11	46	1.7
3.2	11-13	174	146	25	25	12	57	2.1
5	14-16	211	176	31	30	15	70	4
6.3	18-19	252	212	38	35	16	80	7
8	20-22	288	240	44	41	19	95	10
12.6	24-26	329	274	51	51	22	110	15
16	27-29	375	310	57	57	25	130	21
20	30-32	423	350	63	64	28	146	31
20	34-36	474	400	69	64	28	148	37
25	37-39	527	450	76	70	30	153	51
32	40-42	580	500	76	76	33	160	64
40	43-48	643	550	89	89	39	186	96